

EZDown Reloaded Instruction - 1st Fitment

EZDown Reloaded Ford - RL0590

1 THIS KIT IS ONLY TO BE FITTED ON THE RIGHT HAND SIDE OF THIS VEHICLE.

Warranty voided if:
 1. Cable support bracket is not used
 2. If both Cables are not used and Special Washer Item K

Please ensure the cables are free flowing and not over tightened and locked in position.

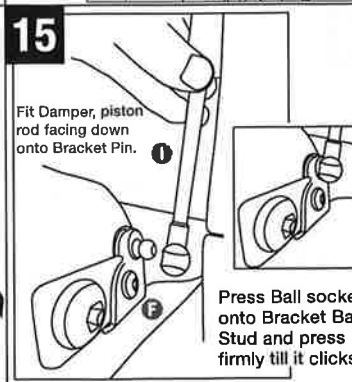
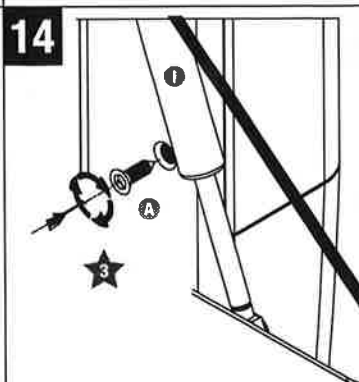
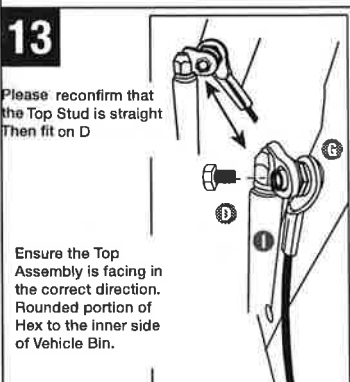
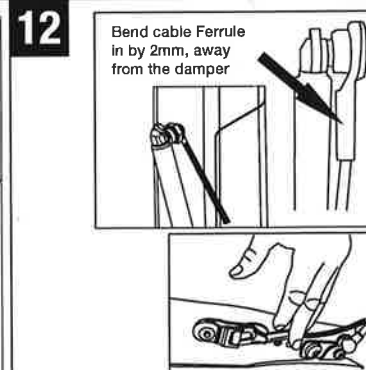
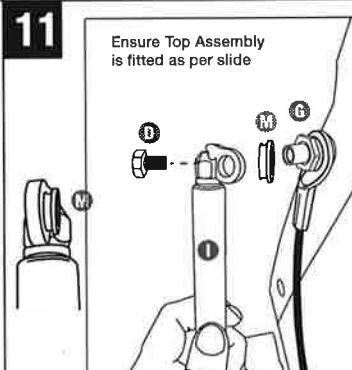
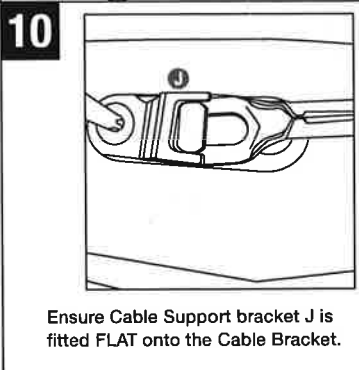
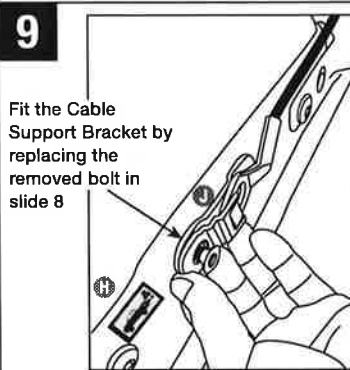
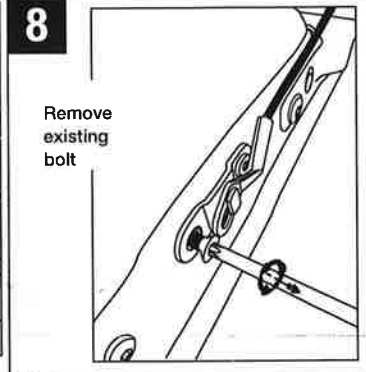
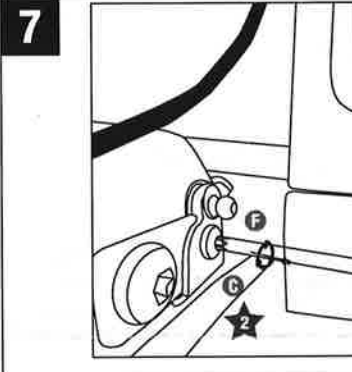
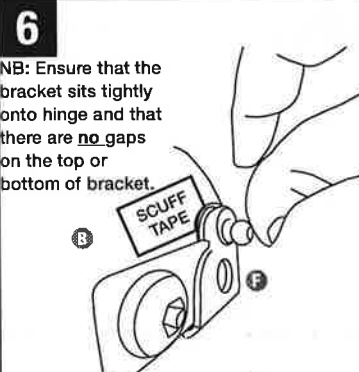
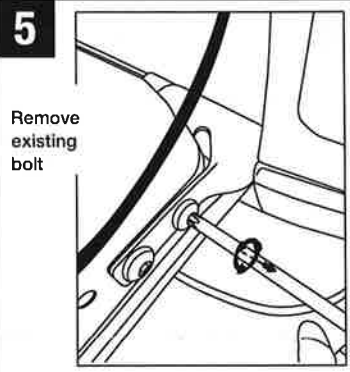
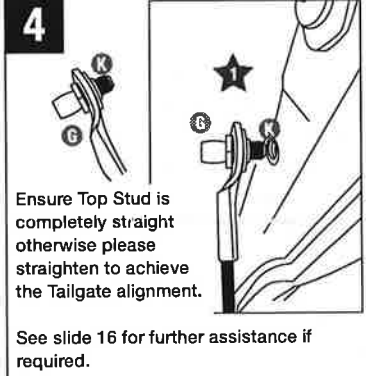
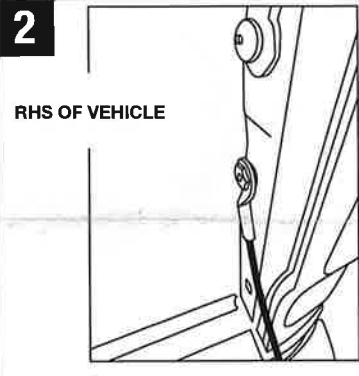

16 Confirm that the Damper has some movement in the tailgate open position therefore ensuring the cables are taking the tailgate weight and not the damper.

Tailgate Alignment procedure:

- Your Tailgate is misaligned when your side top of Tailgate to body is not flush.
- If the tailgate in relation to the body is either set to far inward or outward.

IF THERE IS... Place threaded bar into Top Stud Hole. Tap gently to straighten until your threaded bar is straight.

FITTING CODE	MANUFACTURER	MODEL TYPE	YEAR	STOCKIST	PRODUCT	REVISION	LABOUR	DATE	PAGE
RL0590	FORD	FORD T6	2011 onwards	GENERAL USE	EZDown RELOADED	3	20min	02/10/2018	1
TORQUE - N.m	★ 25N.m ± 2N.m	★ 65N.m ± 2N.m		★ 17N.m ± 2N.m				www.ezdown.co.za	

NB: After installation please close tailgate gently to ensure that there is no interference with any hardware.

IMPORTANT: No liability will be incurred by Industrial Specialised Applications company, for injury, death, or property damage caused by a product which has been set up, operated, and/or installed contrary to EZDown installation guide/manual, or which has been subjected to misuse, negligence, or accident, or which has been repaired or altered by anyone other than Industrial Specialised Applications, or which has been used in a manner or for a purpose for which the product was not designed.

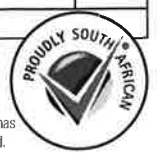

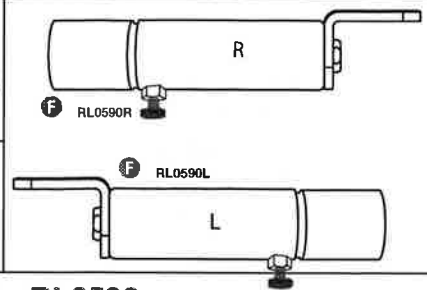

EZDown Reloaded Instruction - 2nd Fitment

EZDown Reloaded Ford - RL0590

1
Right Hand Side (RHS) and Left Hand Side (LHS) are determined when sitting in the Drivers side of the Vehicle.

CAUTION:
Do not remove the red bolt from cylinder E until fully installed - if you do you will loose the pre-tension.

2
Open tailgate.
See slide 4 & 5 for area where nut G needs to be fitted.
Loosen Half a Turn before installing fitting Locking Nut shown in Slide 4

3
Remove the two bolts on RHS & LHS.
Once the bolts are removed the taillights will clip from the vehicle body.

4
Taillight cavity

5

At the bottom install the locking nut G supplied onto the existing bolt. See slide 4. Repeat for LHS.

Replace taillight and bolts.

6 RHS
Tailgate

NB: View direction from inside the Vehicle Bin looking towards the Tailgate
Remove the bolt on the bracket and throw away.

7 Tailgate

NB: View from inside vehicle looking out.
Insert bracket and fasten M8 counter sunk

8
Repeat slides 2 to 7 on LHS.

9

RHS - Fit Cylinder in position shown by sliding over end bolt and will lock in this position - see slide 10

10

Cylinder slides over the bolt on the bracket and then over the stud D. Ensure cylinder locks flush onto the nut.

11

Fix washer and M6 Nut onto stud and fasten when tailgate is still open.

12 Repeat slides 9 to 12 for LHS.

13

REMOVE RED BOLT ON BOTH RHS AND LHS.

14

This is what it will look like on the inside when correctly installed.

15

16
NOTE:
Tailgate will fall very slowly the first cycle in order for the Reloaded to set.
SHOULD YOU WANT TO INCREASE YOUR PRELOAD OR REINSTALL YOUR PRELOAD IF REMOVED FROM THE VEHICLE PLEASE CONTACT YOUR CLOSEST STOCKIST FOR ASSISTANCE

FITTING CODE	MANUFACTURER	MODEL TYPE	YEAR	STOCKIST	PRODUCT	REVISION	LABOUR	DATE	PAGE
RL0590	FORD	FORD T6	2011 onwards	GENERAL USE	EZDown RELOADED	9	25min	15/05/2019	1
TORQUE - N.m		★ 27N.m±2N.m		★ 15N.m±2N.m		www.ezdown.co.za			

NB: After installation please close tailgate gently to ensure that there is no interference with any hardware.

IMPORTANT:

No liability will be incurred by Industrial Specialised Applications company, for injury, death, or property damage caused by a product which has been set up, operated, and/or installed contrary to EZDown installation guide/manual, or which has been subjected to misuse, negligence, or accident, or which has been repaired or altered by anyone other than Industrial Specialised Applications, or which has been used in a manner or for a purpose for which the product was not designed.

