

EZDown Reloaded Instruction
- 1st Fitment

EZDown Reloaded Isuzu RL0450

www.ezdown.co.za

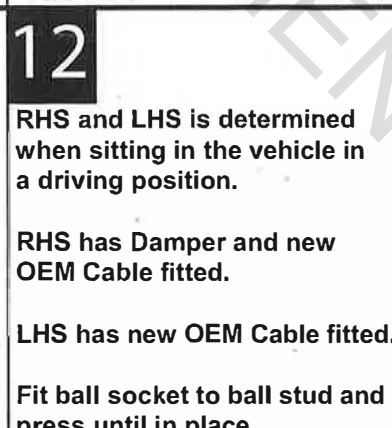
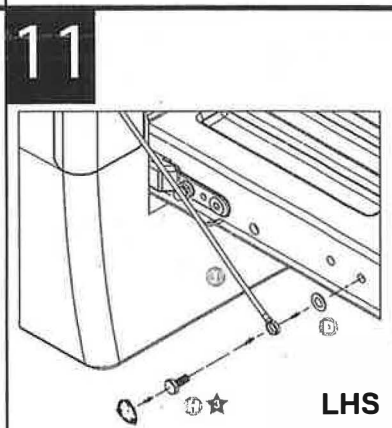
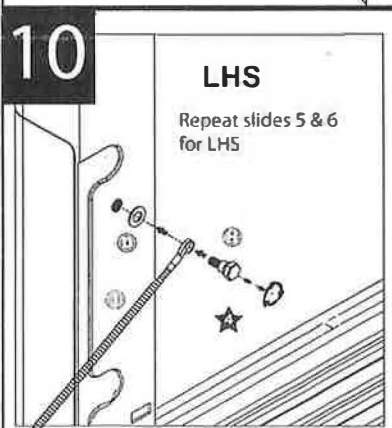
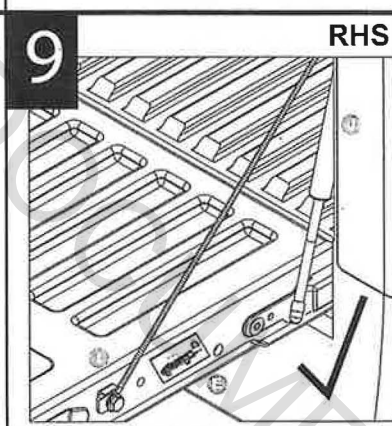
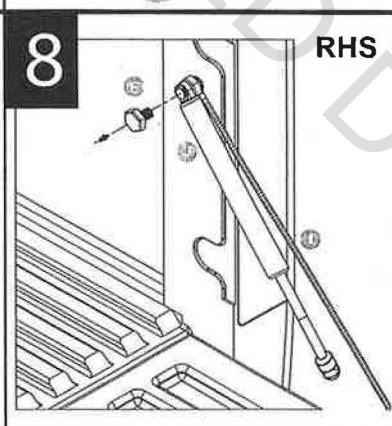
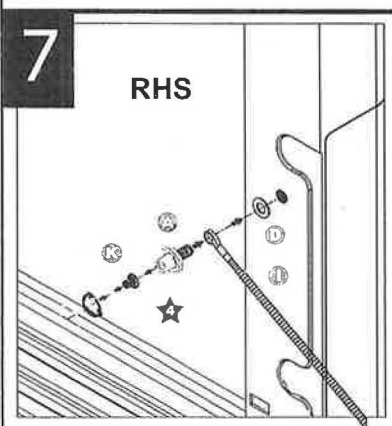
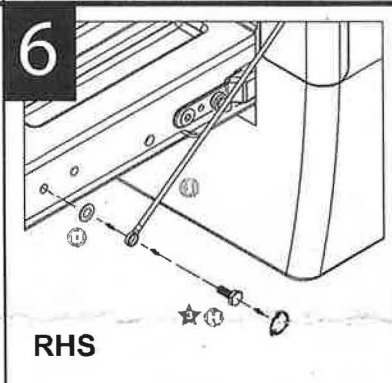
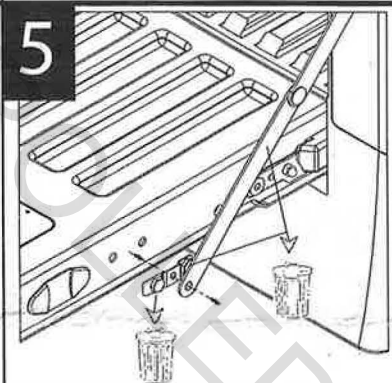
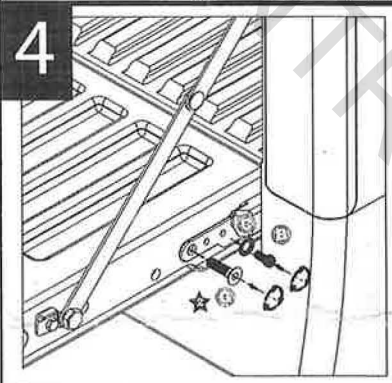
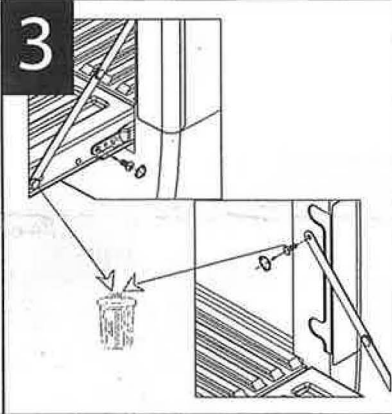
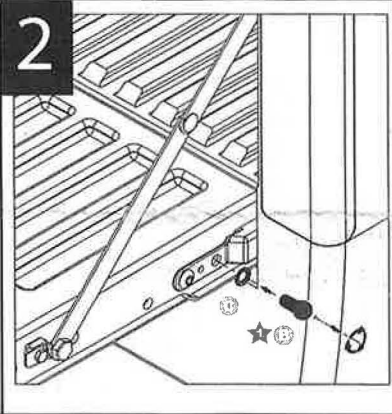
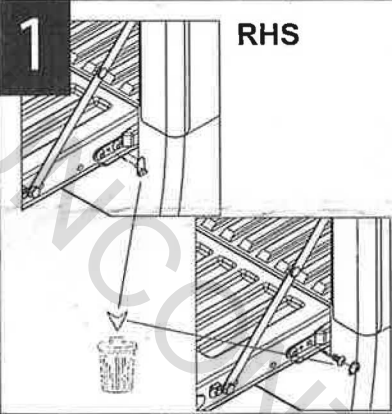

NB: After installation please close tailgate gently to ensure that there is no interference with any hardware.

FITTING KIT CODE	MANUFACTURER	MODEL TYPE	YEAR	STOCKIST	PRODUCT	REVISION	LABOUR TIME	DATE	PAGE
RL0450	ISUZU	KB/D-MAX	2005-2015 1ST INTRO	GENERAL USE	EZDown RELOADED	2	30min	03/05/2018	1
TORQUE-N.m	★ 27N.m±2N.m	★ 17N.m±2N.m	★ 27N.m±2N.m	★ 27N.m±2N.m	★ 27N.m±2N.m	★ 27N.m±2N.m			

IMPORTANT:
No liability will be incurred by Industrial Specialised Applications company, for injury, death, or property damage caused by a product which has been set up, operated, and/or installed contrary to EZDown installation guide/manual, or which has been subjected to misuse, negligence, or accident, or which has been repaired or altered by anyone other than Industrial Specialised Applications, or which has been used in a manner or for a purpose for which the product was not designed.

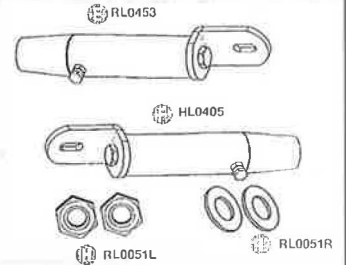
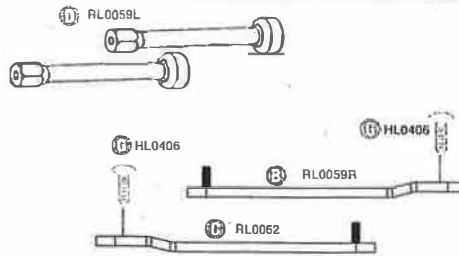
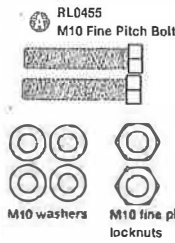

**EZDown Reloaded Instruction
- 2nd Fitment**

EZDown Reloaded Isuzu RL0450

1
RHS and LHS are determined when sitting in the Drivers side of the Vehicle.

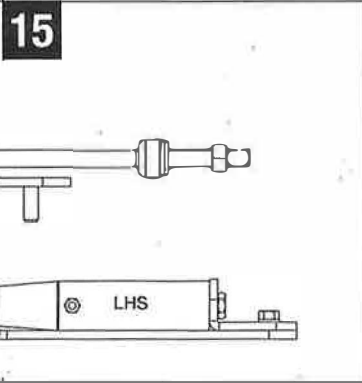
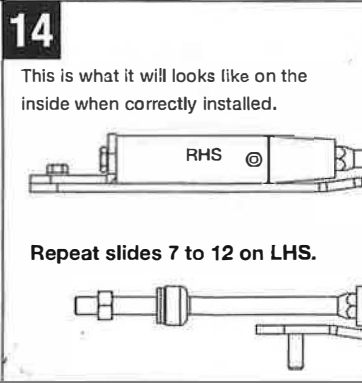
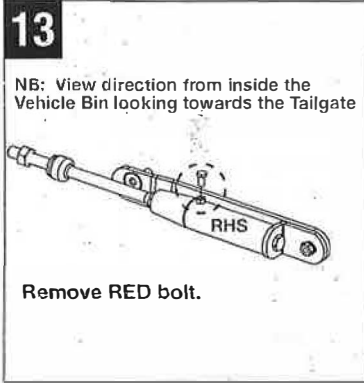
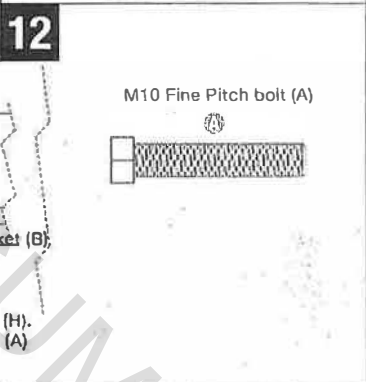
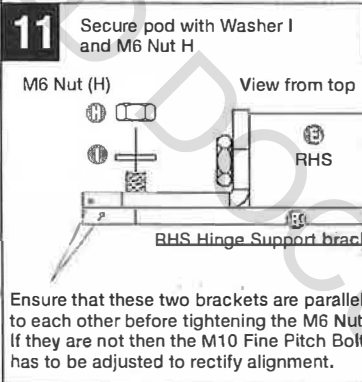
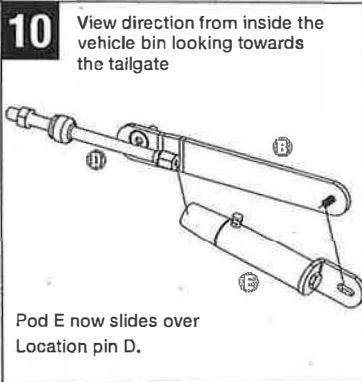
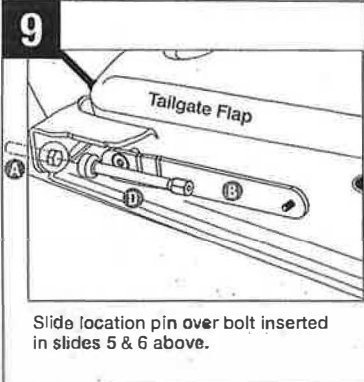
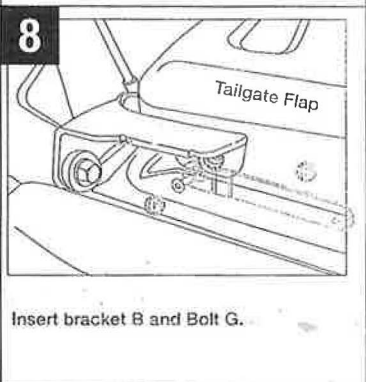
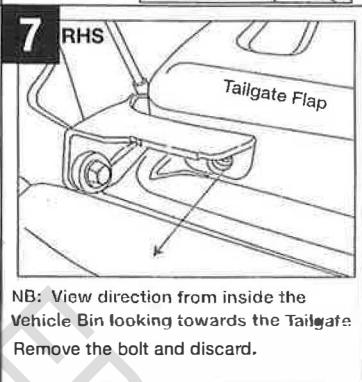
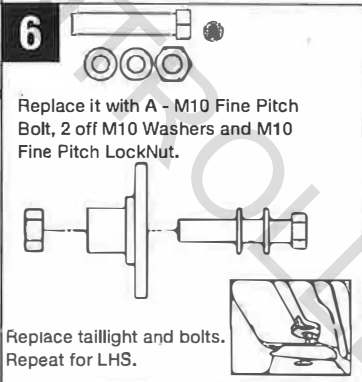
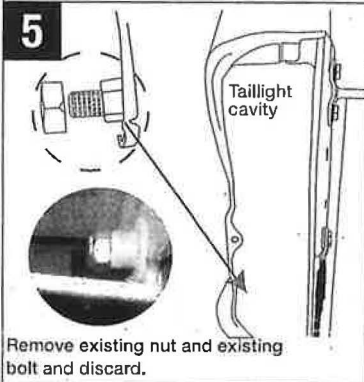
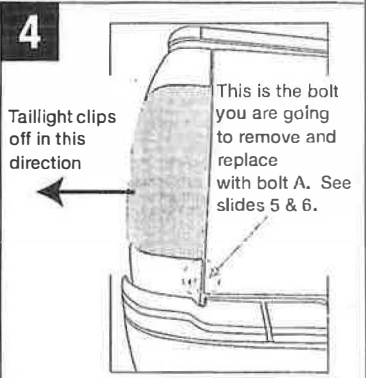
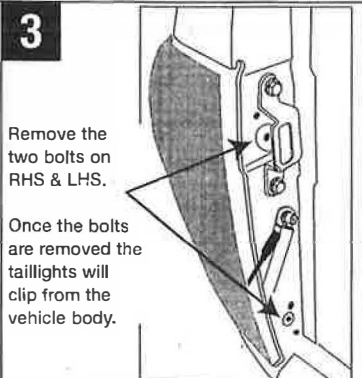
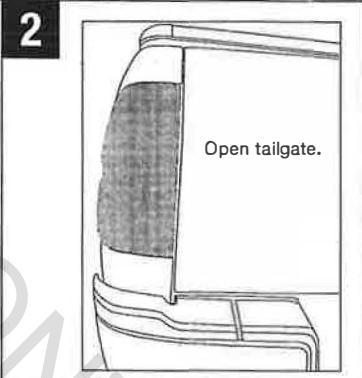

16
NOTE:
Tailgate will fall very slowly the first cycle in order for the Reloaded to set.
SHOULD YOU WANT TO INCREASE YOUR PRELOAD OR REINSTALL YOUR PRELOAD IF REMOVED FROM THE VEHICLE PLEASE RETURN BOTH POD CYLINDERS (ITEM E & F) TO YOUR CLOSEST STOCKIST FOR ASSISTANCE

FITTING CODE	MANUFACTURER	MODEL TYPE	YEAR	STOCKIST	PRODUCT	REVISION	LABOUR	DATE	PAGE
RL0450	ISUZU	KB/D-MAX	2005 TO CURRENT	GENERAL USE	EZDown RELOADED	1	25min	15/08/2018	1
TORQUE - N.m		★ 27N.m±2N.m		★ 15N.m±2N.m		www.ezdown.co.za			

NB: After installation please close tailgate gently to ensure that there is no interference with any hardware.

IMPORTANT:

No liability will be incurred by Industrial Specialised Applications company, for injury, death, or property damage caused by a product which has been set up, operated, and/or installed contrary to EZDown installation guide/manual, or which has been subjected to misuse, negligence, or accident, or which has been repaired or altered by anyone other than Industrial Specialised Applications, or which has been used in a manner or for a purpose for which the product was not designed.

