

FIT 1099

TRUCKMAN

THE UK'S LARGEST HARDTOP MANUFACTURER

INSTALLATION INSTRUCTIONS STYLING BAR KIT FOR RETRAX ROLLER TONNEAU



TOYOTA HILUX MK8

TRUCKMAN PART NUMBER: 8RABRBSTOH8D

1ST EDITION

RETRAX - STYLING BAR

Please read these instructions carefully. If you have any questions regarding the fitting of this item call 01384 485405 or email fitting@truckman.com.

Failure to comply with these instructions may affect any warranty considerations

KIT CONTENTS

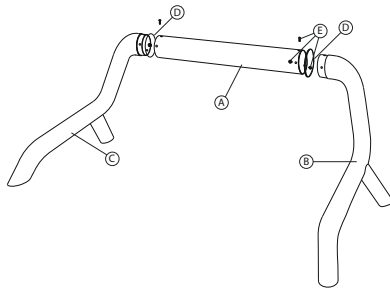

Truckman Styling bar
8BSE4FORA5D or 8BSEB4FORA5D



D - Joint cover O-rings



E - M6 x 20mm hex socket button screws



F - Set of 4 Adapter plates
ZMAT880



G - Set of 4 self adhesive
rubber pads ZRUB841



H - 8 x M10 wafer headed
screws ZFIX1043



I - Set of domed security nuts
& spanner ZFIX900



J - Retrax Accessory Stud set
ZMAT882

TOOLS REQUIRED:
5mm hex driver,
4mm hex driver,
Thread locking solution

Follow the assembly instructions supplied with the Retrax tonneau. Ideally, the Styling bar should be installed with the Retrax tonneau fitted to the vehicle. If this is not possible ensure the tonneau is on a flat surface.

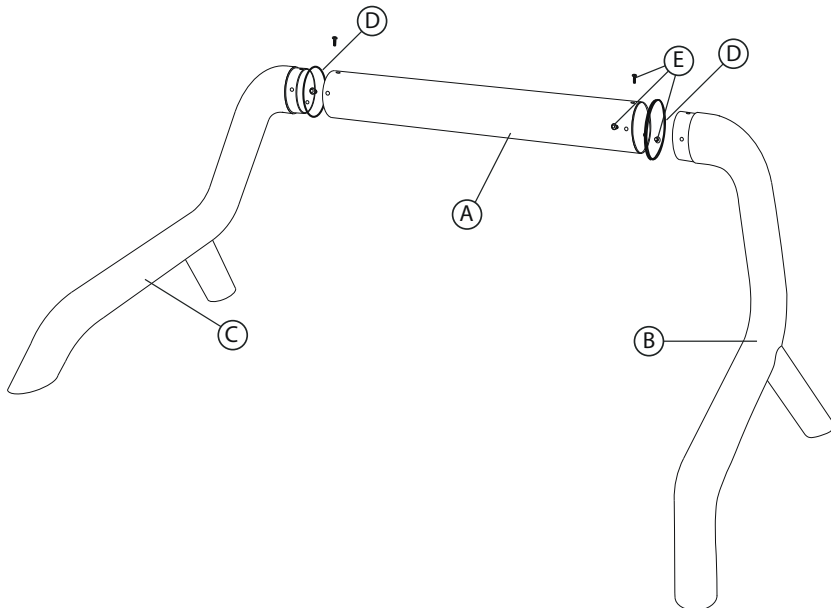



1. Fit a Joint cover O-ring (D) over each end of the centre section of the styling bar (A).



2. Fit the centre (A) and R/H section of the bar (B) together.



3. Fit the screws (E) (using thread locking solution) then slide the joint cover O ring into place.



4. Repeat steps 2 and 3 on the left side with part C.



5. Apply the self adhesive foam pads (G) to the lower side of the adapter plates (F).

NOTE: The lower side of the plates have larger counter bored holes.



6. Use the M10 wafer headed screws (H) to fit the adapter plates to the legs of bar. Leave the screws loose enough to allow the plates a little movement.

NOTE: Ensure the adapter plates are correctly orientated (see photo left)



7. Fit the accessory studs (J) into the groove in the Retrax rail. There is a cut-out in the groove at the tailgate end designed to allow this. Fit two in each rail.



8. Lift the bar on to the Retrax.

RETRAX - STYLING BAR



9. Lower the bar down onto the accessory studs, adjusting the plates if necessary.



10. Use masking tape and a pen to mark the positions of the plates relative to the bar.



11. Remove the bar, apply thread lock to the screws then tighten, carefully maintaining the position of the plates.



12. Refit the bar ensuring the front edge of the plates are 20mm from the front of the tonneau.



13. Remove the masking tape then fit the security nuts (I) with thread lock.



14. Use the spanner supplied to tighten the nuts.

MODELS COVERED:

Truckman Styling Bar & Adapter for: Truckman Retrax Roller Tonneau - Toyota Hilux Mk8 D/C

These instructions are correct at time of publication only and may be amended without notice. For the latest version contact fitting@truckman.com or call us on 01384 485405

Auto Styling
TRUCKMAN
GROUP

Auto Styling Truckman Group Limited,
Unit 14 Narrowboat Way,
Brierley Hill, DY2 0EZ, United Kingdom

Tel: 01384 485 405 **Fax:** 01384 485453

Email: fitting@truckman.com

Web: www.truckman.com

Notice

It is important that safety warnings in the instructions are adhered to.

Do not attempt to fit this product if you are not competent to do so. Improper fitting may affect your warranty considerations.

Due to tolerances of the vehicle fitting of this product may differ from the exact fitting specifications described in the instructions. It is the responsibility of the fitter that the product is installed correctly.

Fitting instruction revisions may be found at www.truckman.com