

TRUCKMAN

ROLL-TOP XTREME

INSTALLATION INSTRUCTIONS

ISUZU DMAX

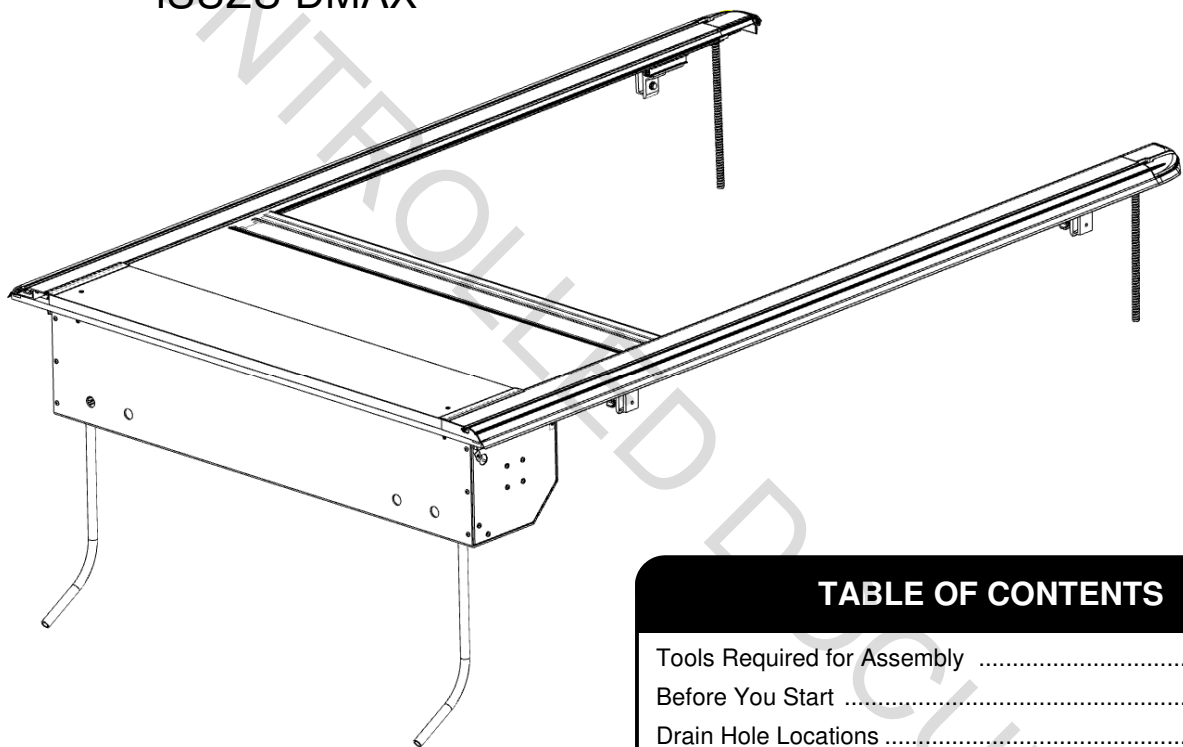

TRUCKMAN

Truckman

Unit 14 Narrowboat Way
Dudley
West Midlands
DY2 0EZ

Telephone: +44 (0) 1384 485405

<http://www.truckman.co.uk>

TABLE OF CONTENTS

Tools Required for Assembly	1
Before You Start	1
Drain Hole Locations	1
STEP 1: Remove From Packaging, and Hardware and Packaging Contents	1
STEP 2: Positioning Canister	2
STEP 3: Installing Rails	2
STEP 4: Installing Top Cover	4
STEP 5: Installing Clamp Extensions	5
STEP 6: Installing the Clamps	6
STEP 7: Installing the Rail Kickstands.....	7
STEP 8: Installing Tailgate Drain Tubes	8
STEP 9: Lubricating & Placing Sweep Seals	9
STEP 10: Installing Canister Drain Tubes	9
STEP 11: Attach the Pull Strap	9
Operating Instructions.....	10
Maintenance	10
Warranty Statement.....	11

TOOLS REQUIRED FOR ASSEMBLY

Tape Measure

Side Cut or Needle Nose Pliers

Masking tape

#2 Phillips Screwdriver

Utility Knife

7/16" (11mm) Nut Driver

Note: There should be no drilling into the truck body needed on most standard or full-size trucks.

BEFORE YOU START!

Read the instructions carefully before you start. If you have any questions regarding the installation please call Truckman at +44 (0) 1384 485405.

CANISTER DRAIN HOLE LOCATIONS:

This tonneau cover is designed to carry rainwater from the cover into the canister and then out through the drains. Most truck models have standard OE drain holes or plastic/rubber access ports in the front of the truck bed. Check to make sure your truck has the OE drain holes so that drilling into the sheet metal is not required. If drilling is necessary, be sure to check the underside of the truck bed for the best location. The holes should be located near the side and as far forward as possible. Use a drill bit suitable for sheet metal (such as a taper drill or step drill). Drill drain tube clearance holes at 3/4" (19mm). This will need to be done before installing the cover.

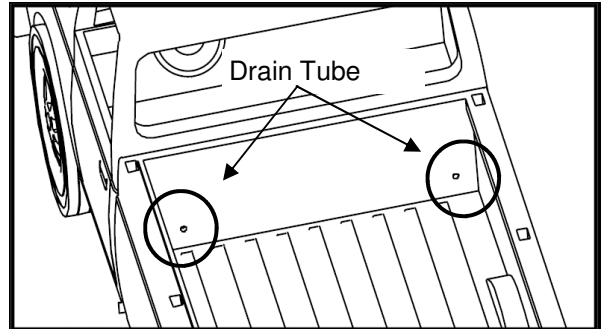

STEP 1: REMOVE FROM PACKAGING AND REVIEW CONTENTS

A complete unit will consist of the Rails, Top Cover, Canister Assembly, Clamp Pack, Hardware Pack, Foam and Drain Tubes. Remove the components from the packaging carefully in order to avoid loss or damage. Perform a quick inventory of the packaging contents to ensure the kit is complete.

PACKAGING CONTENTS:

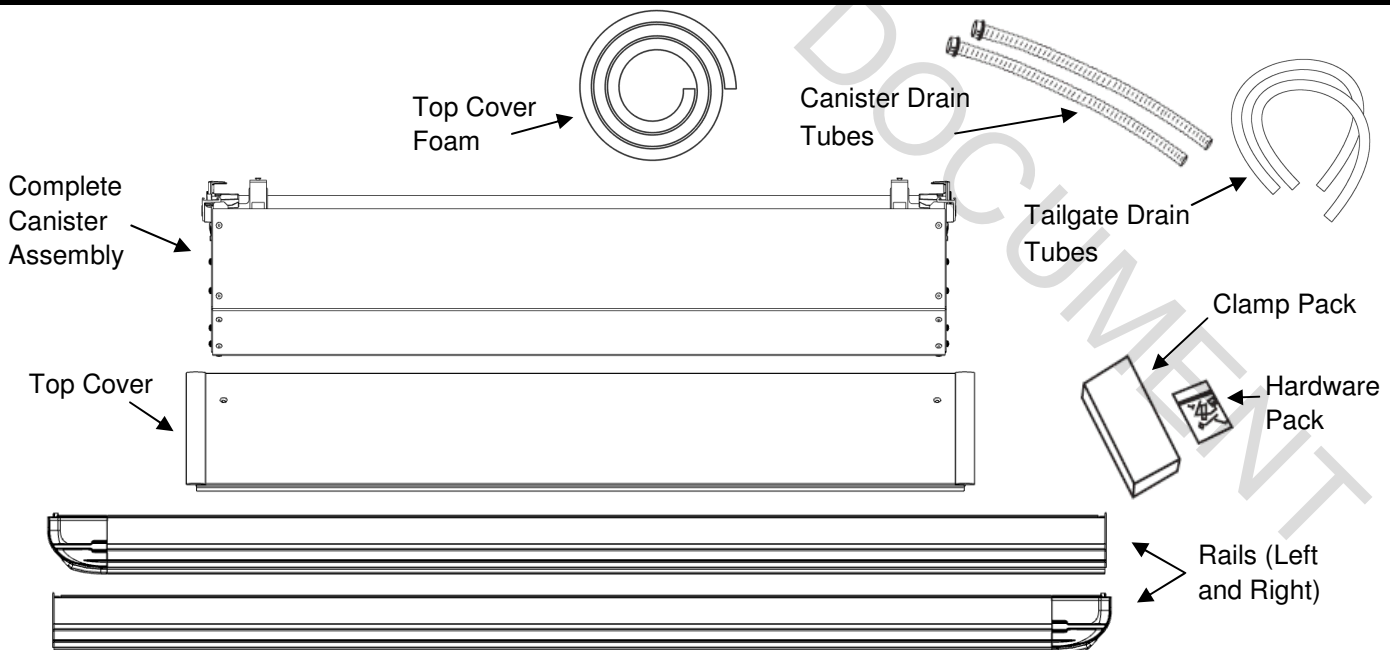

STEP 2: POSITIONING CANISTER

Use the Pull Strap and the canister body to lift and steady the unit. Wrap the Pull Strap around the center of the canister a couple times and double it up in your hand. (If you have someone to help you, you can jump to step 3 and install the assembled canister and rails on the truck)



FIG. 2A

Place the Canister in truck bed just behind the cab and center it from side to side. You will need to place the canister on elevating objects, such as the box the canister came in or buckets. **Note:** Ensuring that the canister is centered in the bed will help with rail installation in the next step.

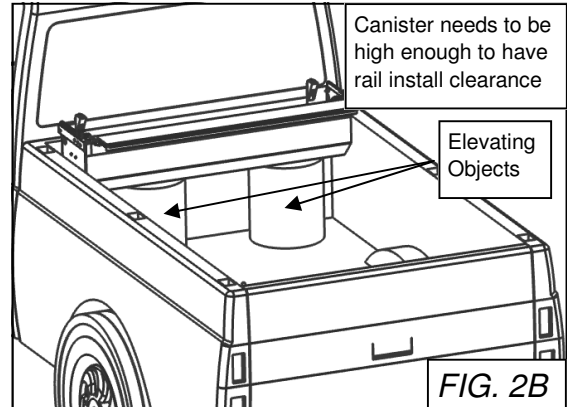

STEP 3: INSTALLING RAILS

Remove the protective paper from the foam on the underside of the Rail flanges. This is for packaging purposes only.

Next identify the left and right side rails (FIG 3A). The rail flange and foam go towards the outside of the truck bed.

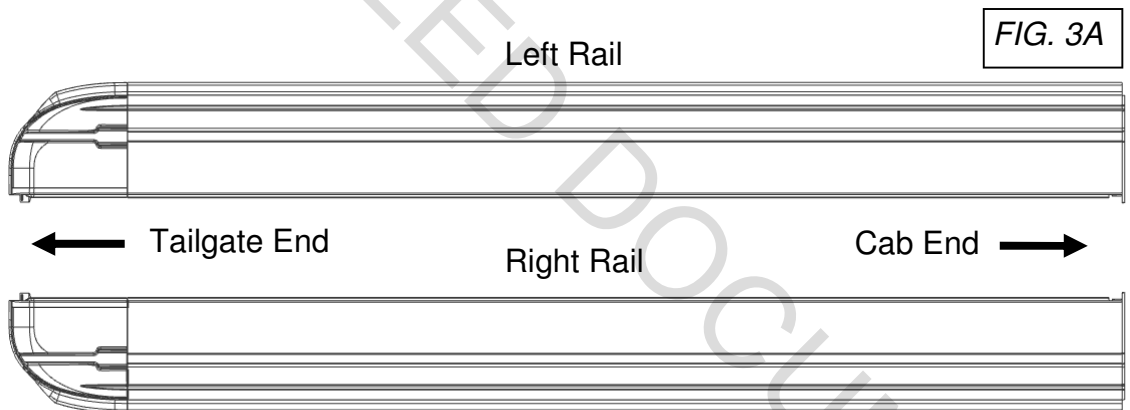
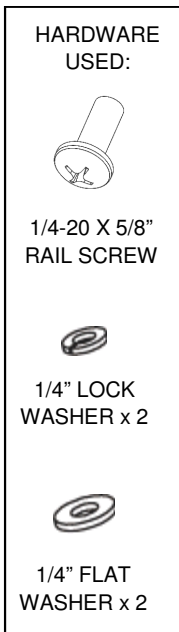

Note: Figure above is for reference only and your supplied rails may be slightly different.

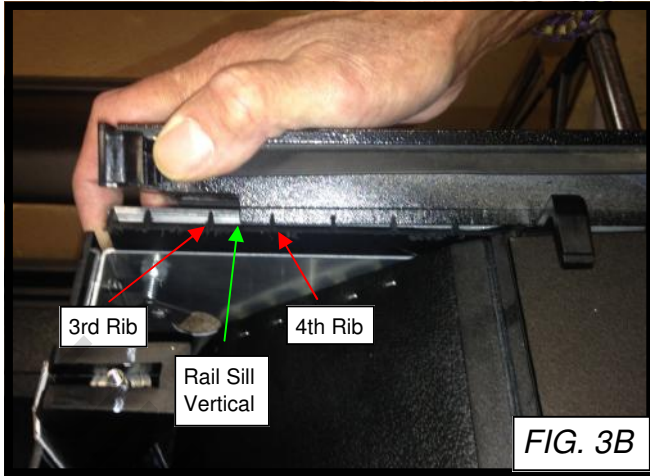

FIG. 3B

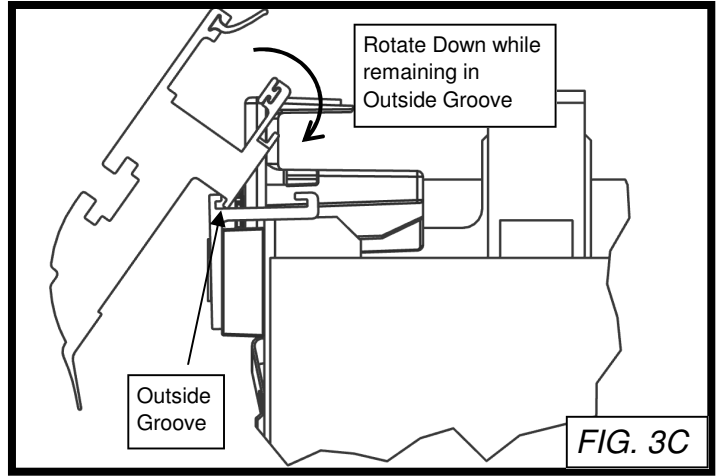

FIG. 3C

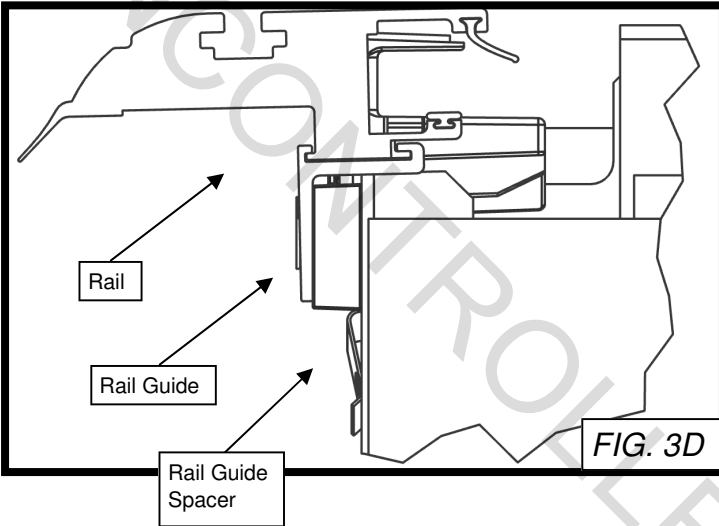

FIG. 3D

First make sure your handle latches are in, this makes the rail install much easier (FIG 3F).

WARNING: IF YOU DO NOT HAVE THE LATCHES IN, THE HANDLE WILL CATCH THE RAIL AS YOU ATTEMPT TO SLIDE IT IN.

Next line up the Rail sill vertical between the 3rd and 4th Rib of the Rail Guide Spacer (FIG 3B). Then hook the Outside Groove of the rail into the Rail Guide and rotate down until the rail and rail guide are level (FIG 3C & 3D). Now push the rail all the way forward (FIG 3E). Finally you can install the Rail Screw, Flat and Lock Washer securing the rail to the canister (FIG 3G).



FIG. 3E

FIG. 3F

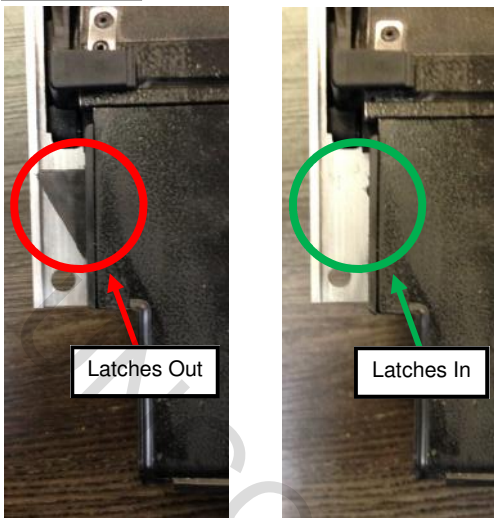

Installing the rails is easier with the handle latches in. For information on handle operation reference Figure 11A.

FIG. 3G

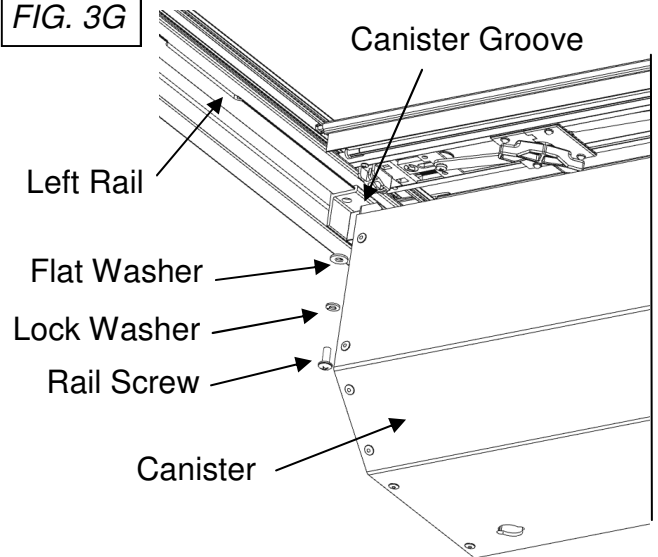

The Rail shown is for REFERENCE and may not exactly match your particular Rail geometry.

STEP 4: INSTALLING THE TOP COVER

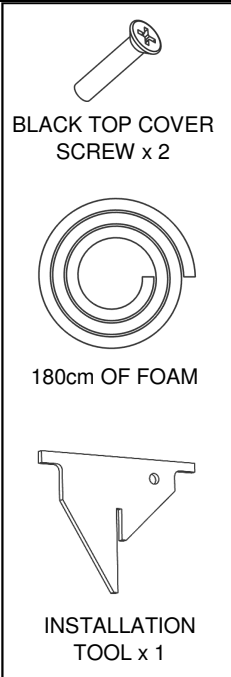

Shut the tailgate and pull the rails back until the tailgate cap seals have good engagement with your tailgate. A good way to check for proper engagement is to make sure the bottom cap and tailgate have a 6mm gap (FIG 4A).

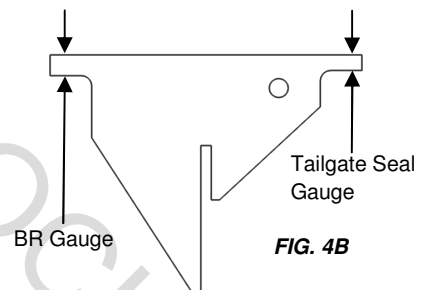
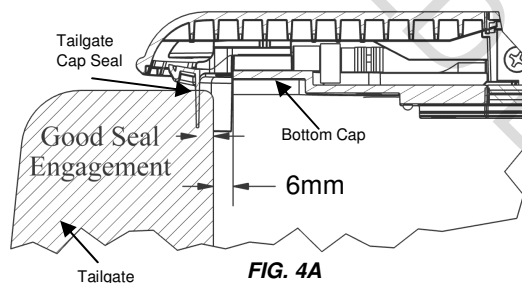

Another way to set the tailgate cap seals is to use the Tailgate Seal Gauge as shown in figure 4B & 4C. You should be able to just slide the Tailgate Seal Gauge in between the Tailgate Cap Seal and the Bottom Cap.

WARNING: Proper Tailgate Cap Seal Engagement is important for getting the best possible water resistance out of your cover!

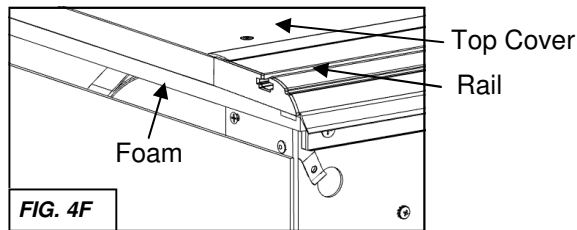
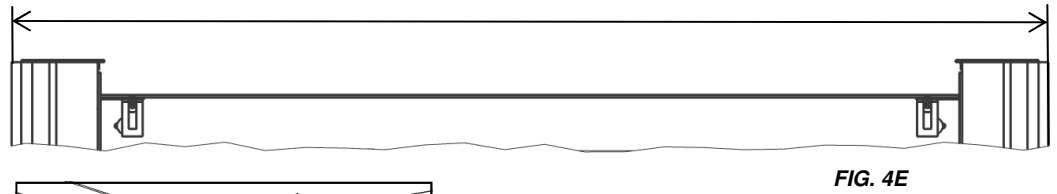
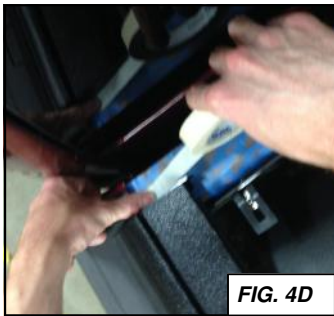

Next mark where the front of the rails sit and mark this position with masking tape, this will be a guide for placing your foam. (FIG 4D). Now pull the cover back until there is room to apply the foam. Lay the foam on the front sill of the truck from rail to rail, trimming the excess with a utility knife (FIG 4E).

Now move the rails and canister back on the foam and double check that your tailgate seal engagement is good. You can now install your top cover with the two included screws while making sure it aligns with the front of your rails (FIG 4F).

WARNING: Proper top cover foam installation is important for getting the best possible water resistance out of your cover!

STEP 5: INSTALLING THE CLAMPS

Before shimming or installing the rail clamps make sure the canister is centered between the truck bed rails. Slide the adjustable clamp shims on each of the 4 clamp extensions (FIG. 5A). Loosen the Adjusting Bolt on the Clamp Shim Bracket and slide the bracket up against the truck bed. Then tighten the Adjusting Bolt (using a 7/16" (11mm) ratchet or nut driver) so the shim is held tight in place.

Assemble the pivot arms to the clamp rail grips and lightly tighten the Clamp Turn Knobs so that the rails rest against the truck bed. (FIG. 5B)

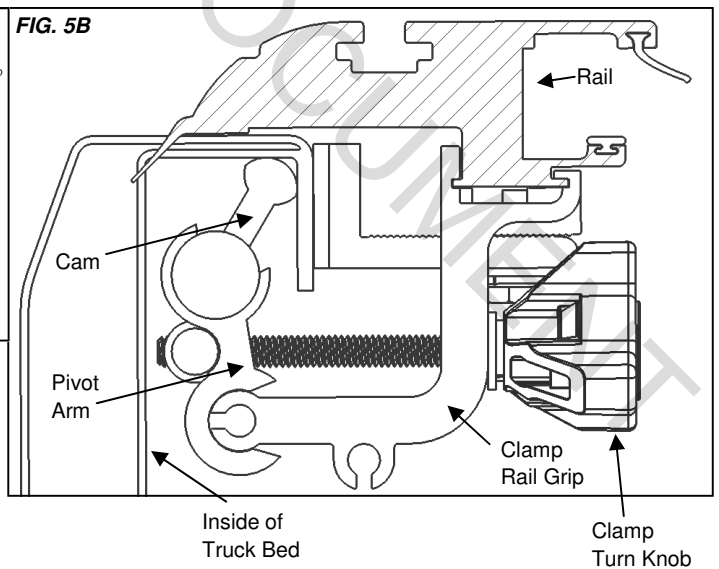
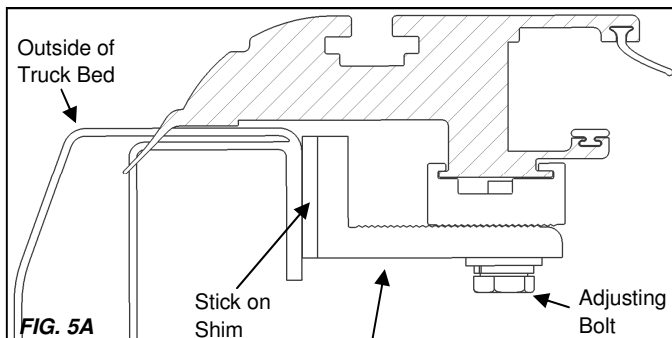

Once the clamps are lightly tightened. Measure the BR dimension at the front and rear of the truck (FIG. 5C & 5D). Another way to ensure proper fit is to check the side to side play of the handle assembly at the canister and at the tailgate end of the rails. There should be, at the minimum, enough play to allow the cover to move freely with no drag and at a maximum 3mm of play per side. If you push the cover to one side you should not be able to fit the BR gauge between the Rail metal and Handle Stop on the opposite side (FIG. 5E). More than 3mm per side of play may result in the cover opening unintentionally and in severe cases it may fall between the rail tracks and damage the cover. The shims should be adjusted until proper fit is achieved.

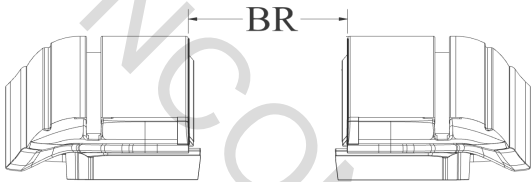

FIG. 5C

Part number is on the serial number label in the upper left corner of the canister (looking from tailgate).

PART NUMBER	BETWEEN THE RAILS
AR and AM2091	54 13/16 (139.2 cm)

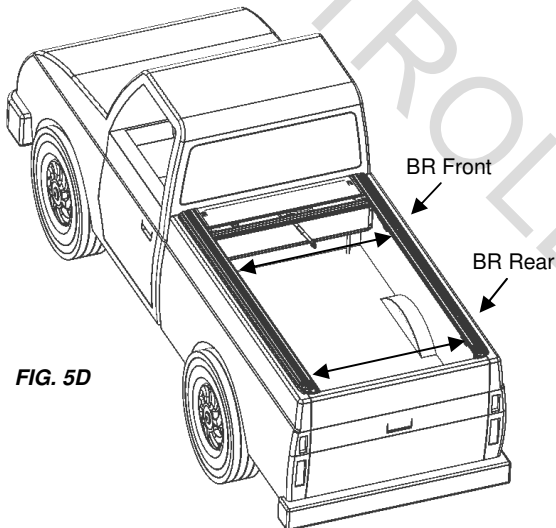

FIG. 5D

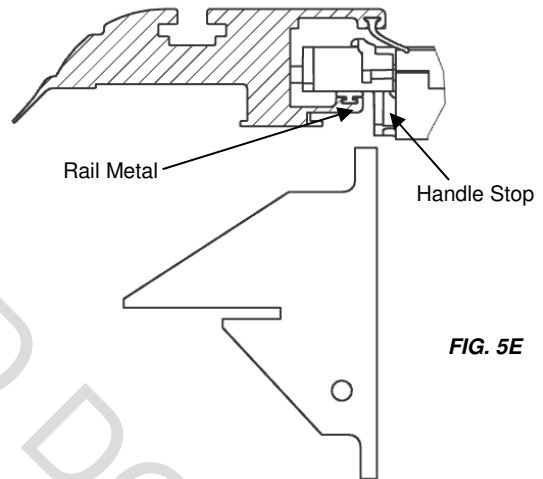
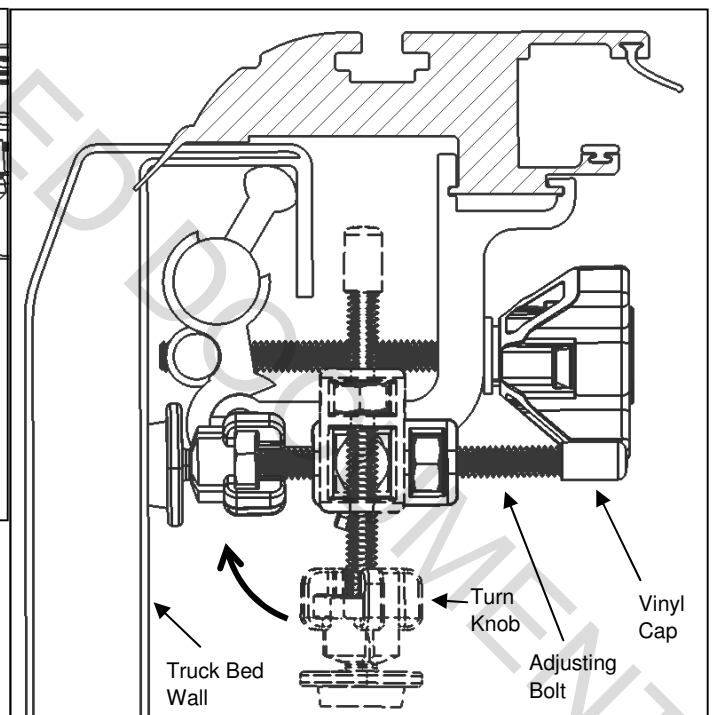
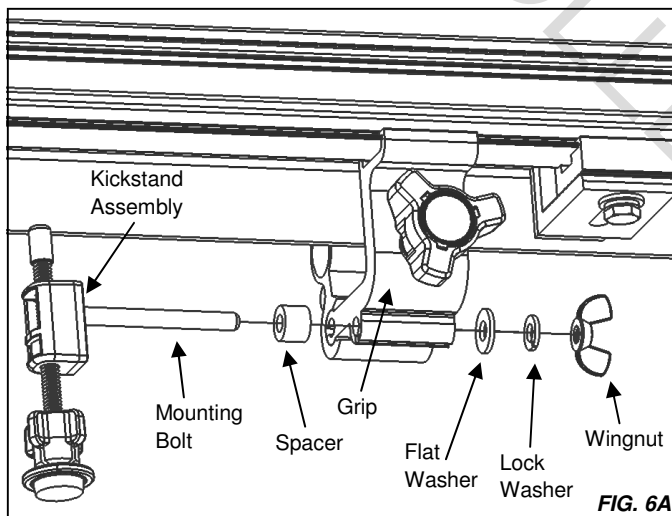

FIG. 5E

STEP 6: INSTALLING THE RAIL KICKSTANDS

Fasten the pre assembled Kickstand Assembly on to each Tailgate end Grip using the provided mounting bolt, spacer, lock washer and wingnut (FIG. 6A). Next swing up the kickstand so that the adjusting bolt so that it is as perpendicular to the Truck Bed wall as possible (FIG. 6B). If you need more or less engagement you can change the length of the Kickstand by flipping Kickstand Base (FIG. 6C). Tighten the Adjusting Bolt first by using the vinyl cap for quick adjustment, fine tuning and higher torque can then be applied using the Turn Knob. Once the rails are level double check that your BR dimension is still good and you can fully tighten the clamps.



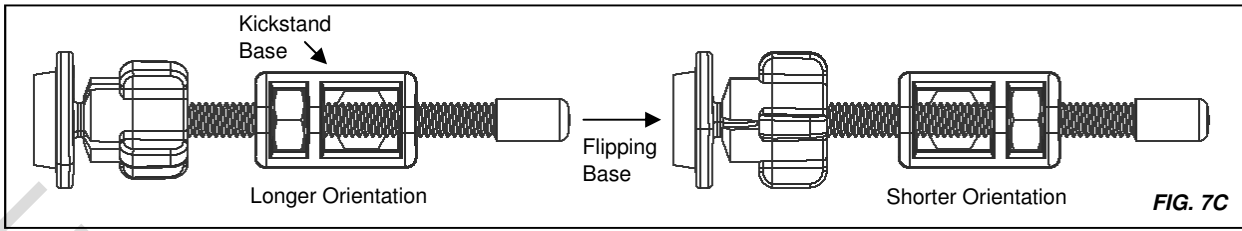

FIG. 7C

STEP 8: INSTALLING TAILGATE DRAINTUBES

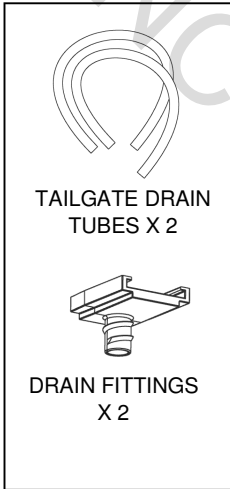
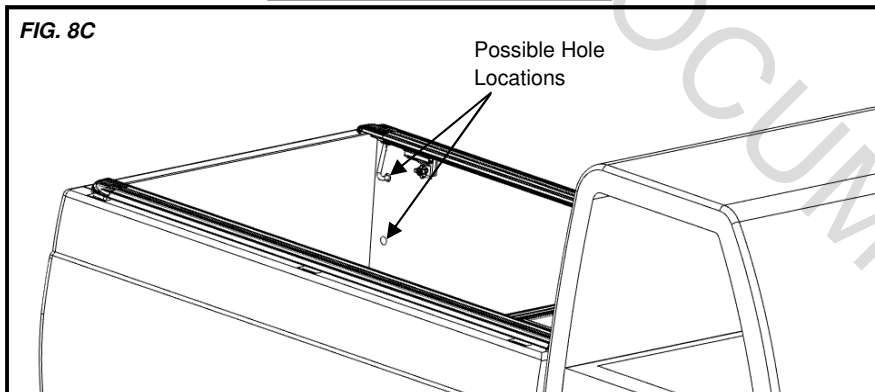
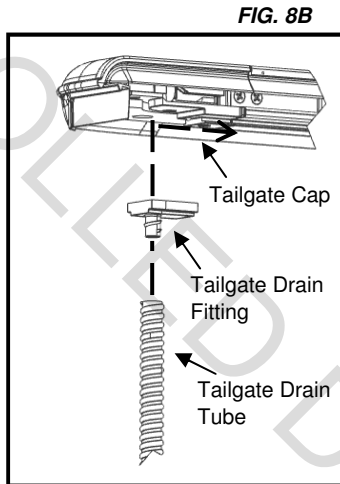

FIG. 8A

To install the tailgate drain tubes you need to find suitable holes in the rear stiffener of your truck bed. Figure 8B shows possible hole locations.

Next you will screw the drain tube onto the drain fitting and slide it on the tailgate cap as shown in figure 8C. There is an interference bump on the cap that will lock the drain fitting in place. Next you will need to thread the drain tube in the desired hole and trim the length of the tube if needed. If there are no holes on the tailgate side of your truck you will need to drill holes (5/8" or 16mm), make sure to check for wires you could damage first.



STEP 9: LUBRICATING & PLACING THE SWEEP SEALS

Locate the sweep seals (rubber weather strips) on the rails. Open the provided 303 brand protectant sponge pack (find it adhered to the underside of the top cover) and wipe the underside of the sweep seal and the top of the wear strip.

Extend the cover to the tailgate. Use an Allen wrench if needed to carefully draw out the sweep seal (seal should be angled outwards toward the cover – not rolled in toward the bed rail). (Fig. 9A)

Proper care and placement of the sweep seal will ensure the smooth operation of the cover. Alcohol, petroleum based or silicon-based UV Protectants such as Armor-All® should be avoided and ARE NOT recommended for our covers.

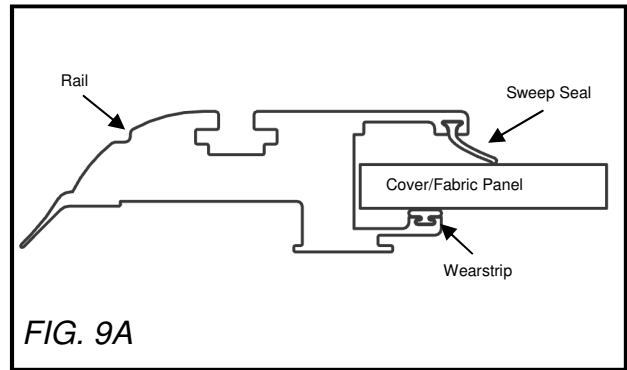

STEP 10: INSTALLING CANISTER DRAIN TUBES

First, ensure that the Foam Washer is in place on the Drain Fitting as this washer will help prevent water leakage. Next, test fit the drain tube to determine the length you want to trim it. Always caution on the long side. Trim the end that will be inserted through the truck bed using the wire cutters or a utility knife.

With the cover *opened*, insert the drain tube fittings into the pre-drilled holes on the underside of the canister by pushing them in place from under the canister. Drain Fitting should click into place.

Place the other end of the drain tube through the plastic/rubber access port or through the pre-drilled holes in the floor or the front wall of the truck bed. If routing through the front wall, ensure that the drain tubes are inserted and directed down so water flows out of the truck.

To remove the drain tubes reach under the canister, grab the drain tube fitting and turn it while applying light downward pressure. When the retaining tabs align with notches in the bottom of the canister the Drain Tube and Fitting will drop out.

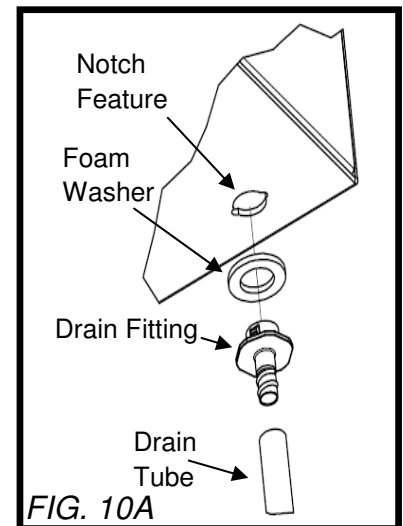

STEP 11: ATTACH THE PULL STRAP



Retract the cover the fully open position. Attach the 10cm Velcro strip onto the Velcro strip already attached to the pull strap. Pull the pull strap over to the driver's side rail and remove the tape from the 10cm Velcro strip. Then apply the Velcro strip onto the underside of the rail at your desired position. This will hold the pull strap off of the floor and out of the way when cargo is being stored in the truck bed.

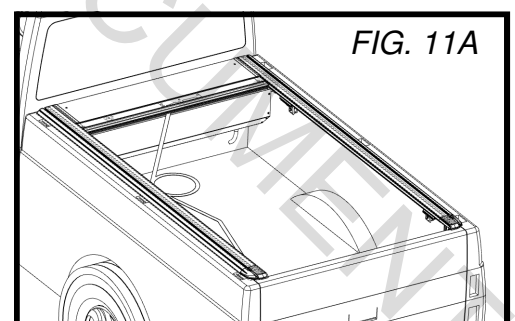

OPERATING INSTRUCTIONS

1. To open the cover, turn the actuator knob clockwise 90° until it clicks in the open position. This retracts the latches into the handle and the cover is free to roll open into the canister. A tug on the pull strap will release the latch and allow the cover to lock into the rails.
2. To latch the cover in one of the mid-range positions, pull it back just beyond the position desired and allow the cover to retract until it latches into place. Latching positions are located every 30cm along the rails. The clicking sound is the spring-loaded latches mounted inside the handle. The latches are designed to bypass the latching positions as the cover is being closed and to stop the cover as it is being retracted.
3. To close the cover, pull on the strap to draw it back toward the tailgate. When it is within easy reach, grasp the handle by the hand grip and pull the cover to the latching position against the tailgate.

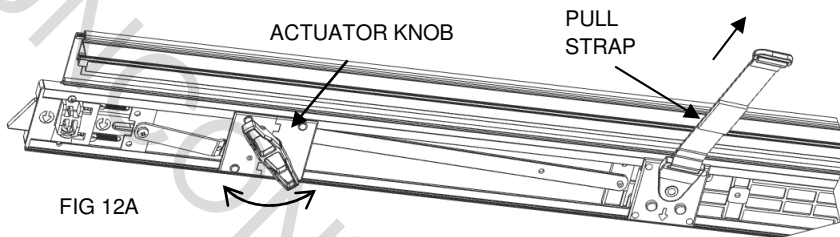

MAINTENANCE

To help keep your Retractable Tonneau Cover looking it's best, we recommend washing it the same as caring for your truck finish. However you should not wax your cover. Using a citrus-based vinyl cleaner and protectant such as 303 brand protectant will keep your cover looking like new.

To assure quiet, smooth operation, periodically apply a generous amount of the same 303 brand or equivalent protectant to a rag and wipe out the inside of the rails the underside of the sweep seal and the top of the wear strip. Repeat as needed until these components are cleaned of debris and well lubricated.

Ensure proper placement of the sweep seal as shown in step 9. Re-apply protectant/lubricant if the cover begins squeaking or sticking during use. (FIG. 9A)

Alcohol, petroleum based or silicon-based cleaners such as Armor-All® should be avoided and ARE NOT recommended for our covers.

It is important to open and close the cover regularly; the spring that operates the cover is self-lubricated and regular use assures that it stays in proper working condition.

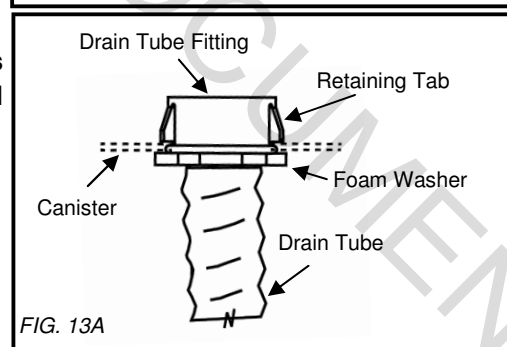
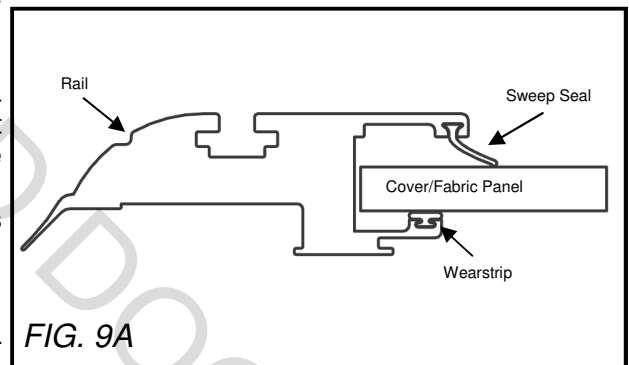

Periodically remove the Top Cover and clean out the inside of the canister.

Drain tubes may become clogged overtime and should be removed and cleaned. To remove the drain tubes reach under the canister, grab the drain tube fitting and turn it while applying light downward pressure. When the retaining tabs align with notches in the bottom of the canister the Drain Tube and Fitting will drop out. (FIG. 10A and 13A)

CONGRATULATIONS!

On your purchase of a Roll-Top Xtreme by Truckman. We are confident that you will get many years of trouble free service from this accessory on your truck.

TRUCKMAN PRODUCT WARRANTY

Truckman (hereinafter referred to as the MFG.) warrants each new Roll-Top Xtreme retractable truck bed cover to the original owner as follows:

FOR A PERIOD OF 3 YEARS FROM THE DATE THE UNIT IS DELIVERED TO THE FIRST PURCHASER:

- Delamination of the Fabric Panel Assembly
- Failure of the Continuous Tension Spring
- All hardware and components

ITEMS NOT COVERED UNDER WARRANTY FOR ANY PERIOD OF TIME:

- Rips, tears, or discoloration of the Fabric Panel material
- Seals and gaskets
- Water intrusion from any source
- Dealer and/or purchaser installed parts and accessories

CERTAIN CONDITIONS WILL VOID ALL WARRANTY.

These conditions include:

- Use for any purpose other than normal private use including rental and promotion
- Altering the retractable truck bed cover in any manner without written approval of the MFG
- Misuse, negligence or accident
- Installation of any part or accessory without written approval from the MFG

CLAIMS:

If you have any warranty issues, please contact Truckman at +44 (0) 1384 485405 with the original invoice, the Unit Model and Serial Number. After determining the validity of the warranty claim, Truckman will ship a replacement part prepaid to the customer. Labour costs to replace defective parts are the responsibility of the purchaser.

CONDITIONS AND LIMITATIONS

This warranty is subject to certain conditions and limitations including, but not limited to, the following:

- Any part of a Roll-Top Xtreme by Truckman retractable tonneau that is found to be defective under the terms of this warranty will be repaired or replaced using either new or reconditioned parts at the discretion of the MFG.
- In determining what constitutes a failure under the terms of this warranty the decision of the MFG shall be final.
- This warranty is extended to the original purchaser only and is not transferable to subsequent purchasers.
- The MFG does not accept any responsibility in connection with the installation of any of its products by its dealers or agents.
- The MFG does not undertake responsibility to any purchaser for warranty express or implied by any of its dealers, distributors or agents beyond that which is contained herein.
- Without regard to an alleged defect of its products the MFG under any circumstances does not assume responsibility for loss of time, inconvenience, revenue, or other consequential damage including, but not limited to, expenses for telephone, food, lodging, travel, loss or damage to the vehicle the products are installed on or loss or damage to personal property of the purchaser or user of the products.
- The MFG reserves the right to make changes in the design of, improvements to, or warranty of its products without imposing any obligation upon itself to provide the same for any products theretofore manufactured.

Some jurisdictions do not allow limitations on or exclusions to warranties, therefore some of the exclusions may not apply to you. This warranty affords you specific legal rights. You may have other legal rights that may vary from jurisdiction to jurisdiction.



Truckman
Unit 14 Narrowboat Way
Dudley
West Midlands
DY2 0EZ

Telephone: +44 (0) 1384 485405

<http://www.truckman.co.uk>